

PAGE 1 CONTROLS T18912-1
TE-M CAN

REVISIONS		
ISSUE	DESCRIPTION	APPD/DATE
1	ORIGINAL ECN#508458 TRS 9-6-23	AAR/KMD 9-13-23
2	ADDED -5 AND -6 ECN#508867 TRS 11-15-23	AAR/KMD 11-16-23

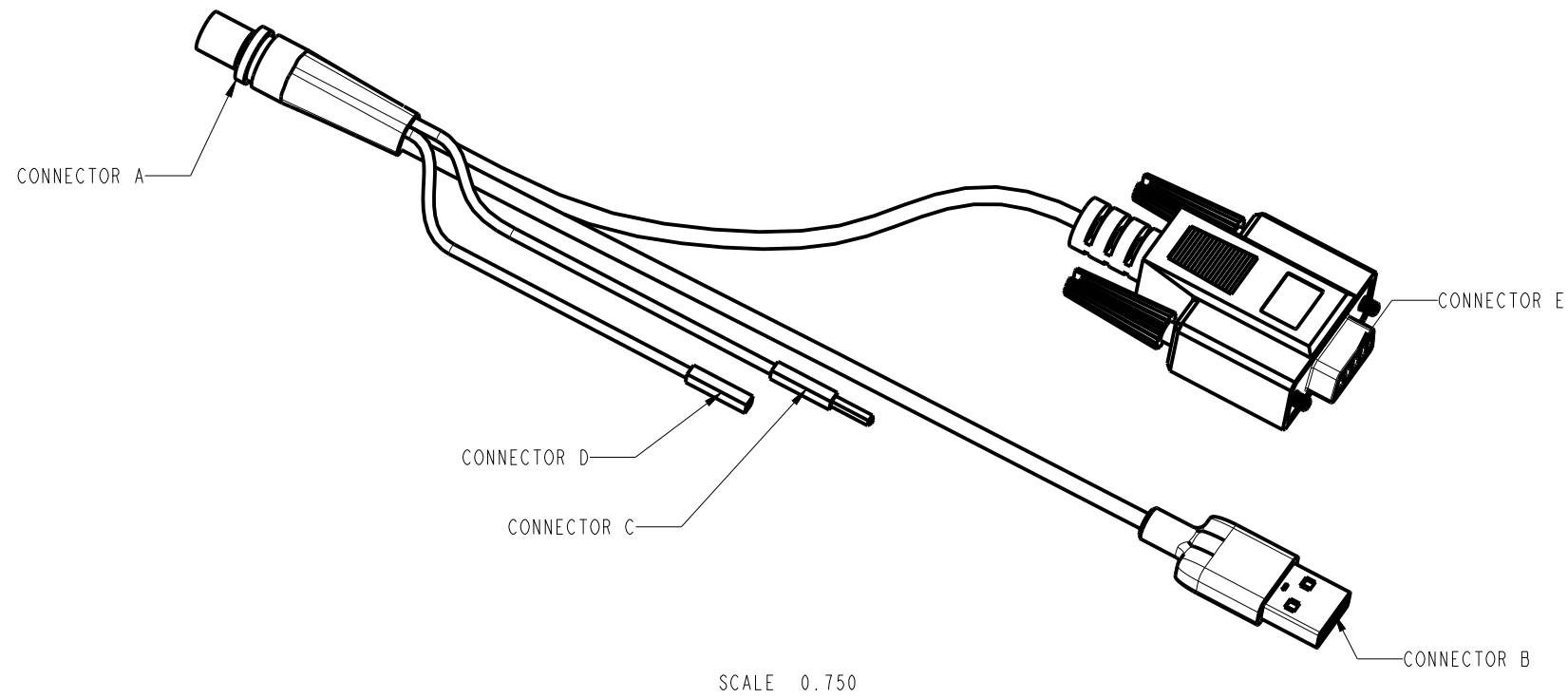

SCALE 0.750

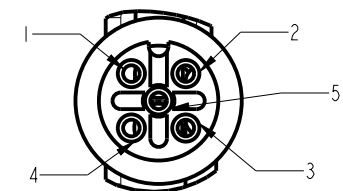
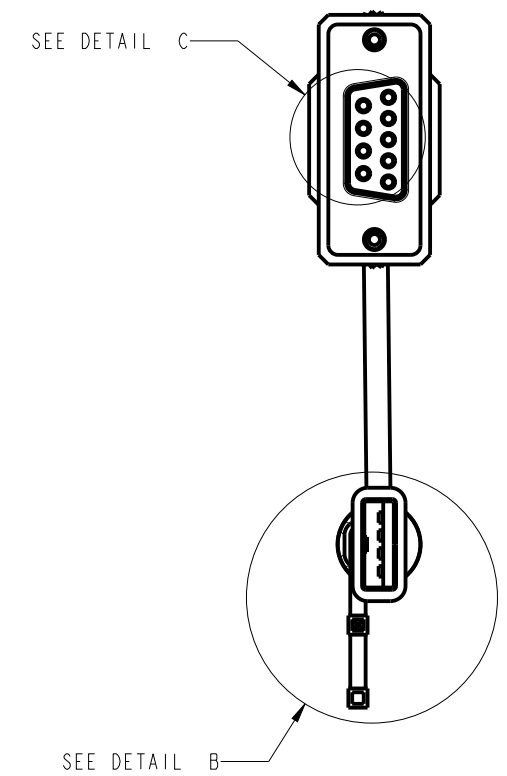
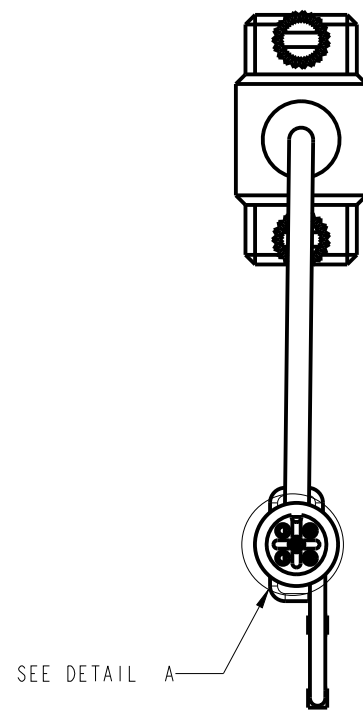
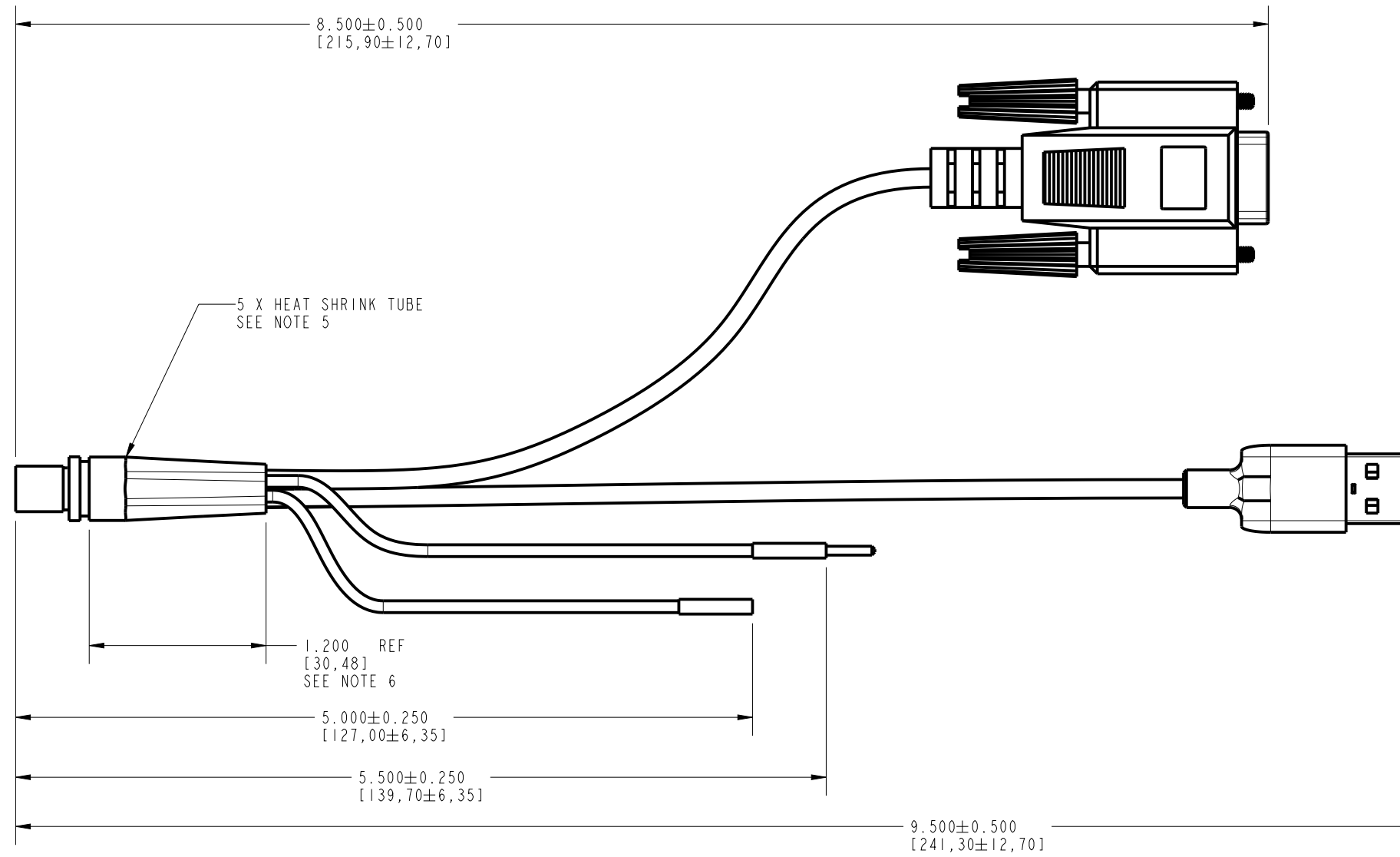

DETAIL A
CONNECTOR A
SCALE 2.000

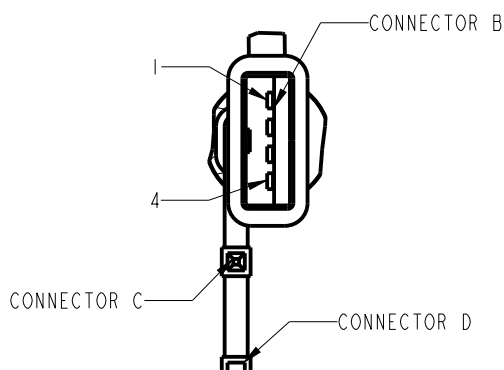

DETAIL B
CONNECTOR B
CONNECTOR C
CONNECTOR D
SCALE 1.500

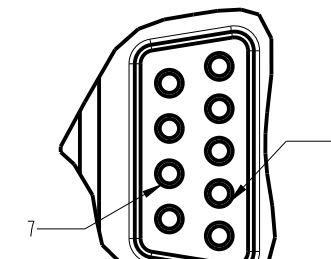

DETAIL C
CONNECTOR E
SCALE 2.000

- NOTES:
- CONNECTOR:
 - A: NORCOMP INC. P/N: 858-005-203RSU4 WITH METAL NUT REMOVED.
 - B: USB A MALE
 - C: MALE JUMPER WIRE SINGLE CONTACT HEADER (SIMILAR TO DIGIKEY: PRT-12794)
 - D: FEMALE JUMPER WIRE SINGLE CONTACT HEADER (SIMILAR TO DIGIKEY: PRT-12794)
 - E: FEMALE DB9 (SIMILAR TO DIGIKEY: MHDPPK9-DB9S-K)
 - CONNECTOR A PINS TO CONNECT TO CORRESPONDING CONNECTOR B, C, D, AND E TERMINALS ON THE CONNECTOR (SEE TABLE)
 - WIRE LENGTH SHOULD BE MEASURED WITH WIRES STRAIGHT.
 - WIRE PULLOUT FORCE MUST BE 2 LBS. MINIMUM.
 - HEAT SHRINK TUBING TO BE USED OVER ALL SOLDER CONNECTIONS.
 - EXTRA THICK HEAT SHRINK TUBING TO BE USED OVER CONNECTOR A CONNECTIONS.

WIRE #	CONNECTOR A	CONNECTOR B	CONNECTOR C	CONNECTOR D	CONNECTOR E	COLOR	DESCRIPTION
	PIN	PIN	PIN	PIN	PIN		
1	1	N/C	1	---	N/C	UNIQUE	MODE
2	2	1	---	---	N/C	RED	PWR
3	3	4	---	1	N/C	BLK	GND
4	4	N/C	---	---	7	YELLOW	CAN H
5	5	N/C	---	---	2	GREEN	CAN L

THIS DRAWING IS AT DESIGN STATUS

ALL REVISIONS TO THIS DRAWING MUST BE MADE IN THE PRO/E SYSTEM

DRAWING UNITS: INCHES [MILLIMETERS]

DRAWING TOLERANCES UNLESS OTHERWISE SPECIFIED:

LINEAR ±	***UNDEFINED***	RADIUS ±	SAME AS DIA
DIAMETER ±	***UNDEFINED***	ANGLE ±	NA

GRAYHILL 361 W HILLGROVE AVE LA GRANGE, IL 60525 708-354-1840 3RD ANGLE PROJECTION

CRITICAL CHARACTERISTIC FLAG PER GRAYHILL SPEC. SOP2338 THIS DRAWING SHALL MEET THE REQUIREMENTS OF GRAYHILL PPAP SPECIFICATION SOP2324 CURRENT REVISION. THIS SPECIFICATION APPLIES TO PURCHASED COMPONENTS ONLY.

DESCRIPTION: TE CABLE

DRAWING NUMBER: T18912-X

SCALE 1.000

T18912-1 #.1 PART

ISSUE: 2

SHEET 1 OF 6

PAGE 2 CONTROLS T18912-2
TE-M USB

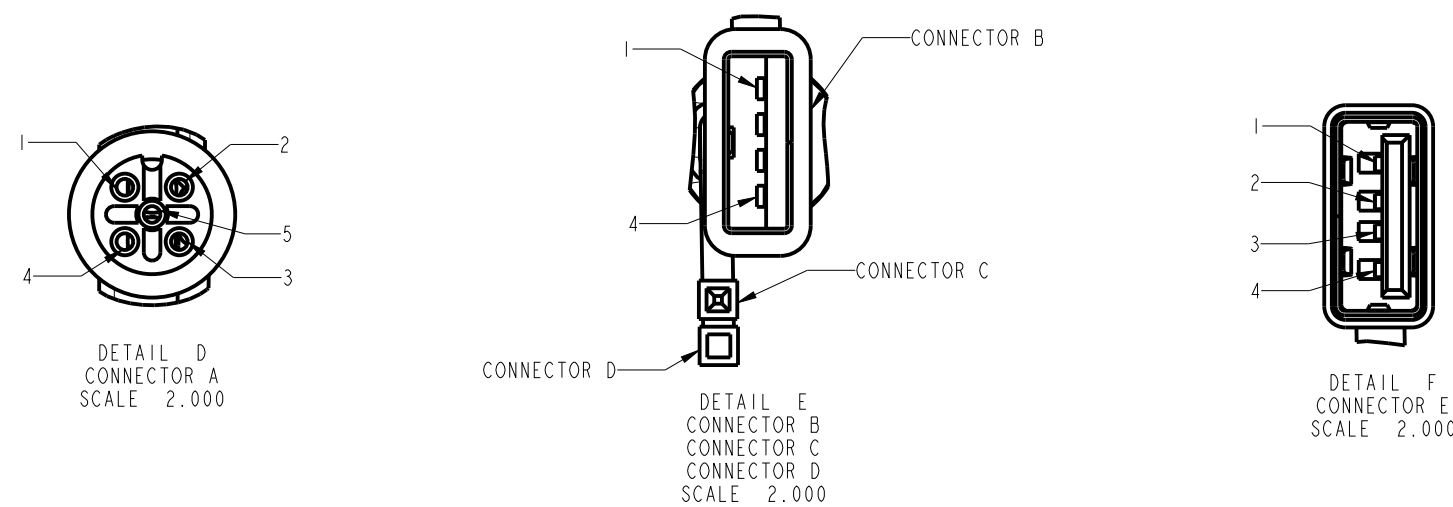
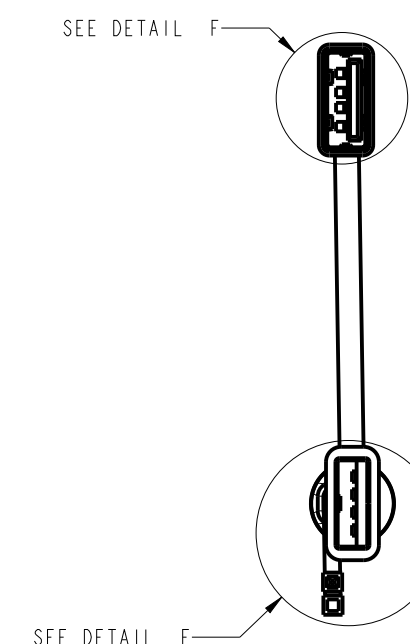
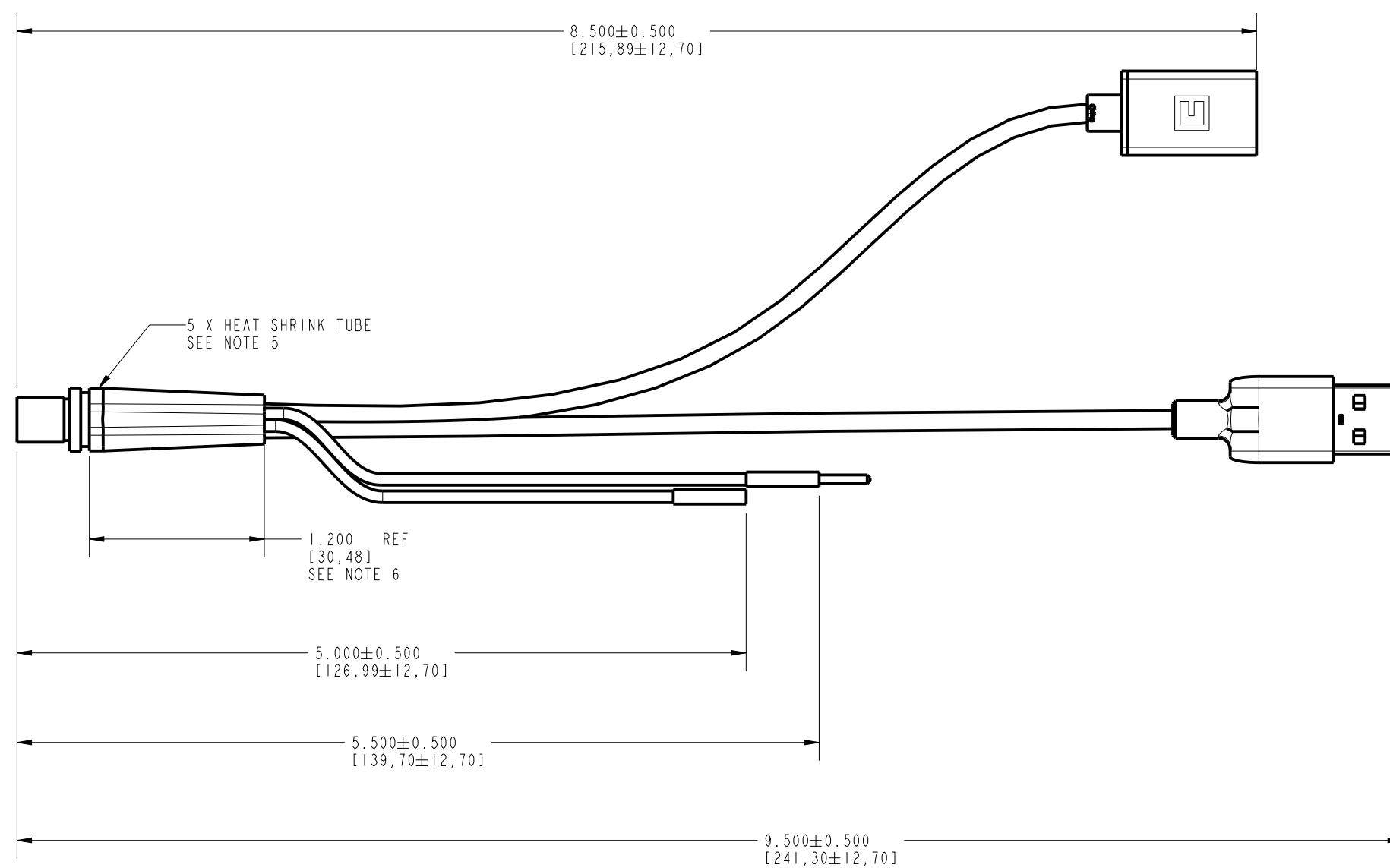
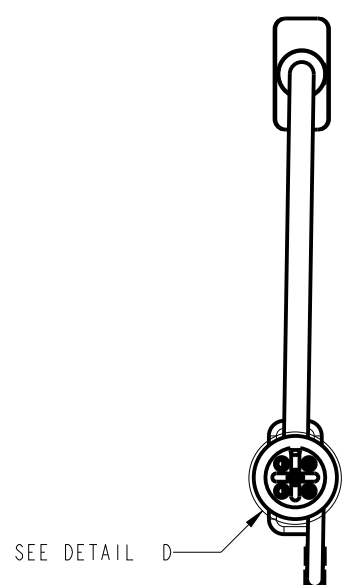
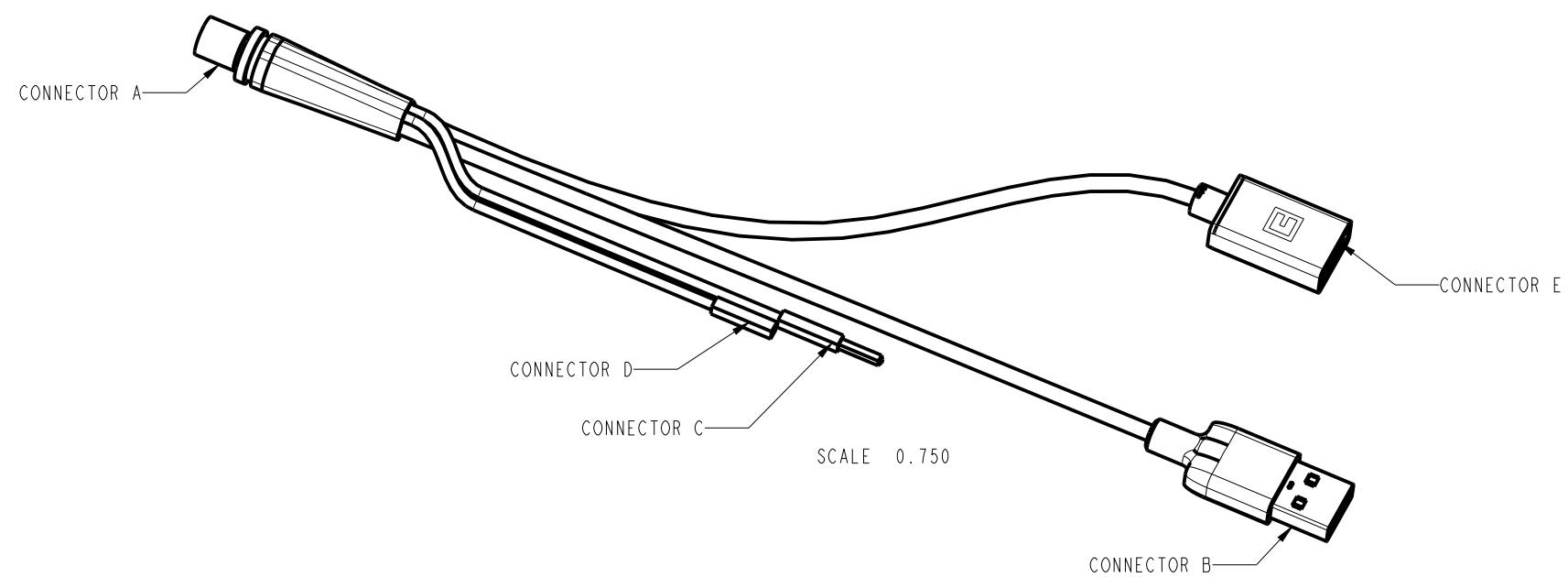

- NOTES:
 1. CONNECTOR:
 A: NORCOMP INC. P/N: 858-005-203RSU4 WITH METAL NUT REMOVED.
 B: USB A MALE
 C: MALE JUMPER WIRE SINGLE CONTACT HEADER (SIMILAR TO DIGIKEY: PRT-12794)
 D: FEMALE JUMPER WIRE SINGLE CONTACT HEADER (SIMILAR TO DIGIKEY: PRT-12794)
 E: FEMALE USB A (SIMILAR TO DIGIKEY: 10-02336)
 2. CONNECTOR A PINS TO CONNECT TO CORRESPONDING CONNECTOR B, C, D, AND E TERMINALS ON THE CONNECTOR (SEE TABLE)
 3. WIRE LENGTH SHOULD BE MEASURED WITH WIRES STRAIGHT.
 4. WIRE PULLOUT FORCE MUST BE 2 LBS. MINIMUM.
 5. HEAT SHRINK TUBING TO BE USED OVER ALL SOLDER CONNECTIONS.
 6. EXTRA THICK HEAT SHRINK TUBING TO BE USED OVER CONNECTOR A CONNECTIONS.

WIRE #	CONNECTOR A PIN	CONNECTOR B PIN	CONNECTOR C PIN	CONNECTOR D PIN	CONNECTOR E PIN	COLOR	DESCRIPTION
1	1	N/C	1	---	N/C	UNIQUE	MODE
2	2	1	---	---	1	RED	PWR
3	3	4	---	1	4	BLK	GND
4	4	N/C	---	---	3	GREEN	USB +
5	5	N/C	---	---	2	WHITE	USB -

THIS DRAWING IS AT DESIGN STATUS		ALL REVISIONS TO THIS DRAWING MUST BE MADE IN THE PRO/E SYSTEM	
DRAWING UNITS: INCHES [MILLIMETERS]		DRAWING TOLERANCES UNLESS OTHERWISE SPECIFIED:	
LINEAR ±	***UNDEFINED***	RADIUS ±	SAME AS DIA
DIAMETER ±	***UNDEFINED***	ANGLE ±	NA
GRAYHILL 361 W HILLGROVE AVE LA GRANGE, IL 60525 708-354-1840		SIZE C <small>3RD ANGLE PROJECTION</small>	
CRITICAL CHARACTERISTIC FLAG PER GRAYHILL SPEC. SOP2338		<small>THIS DRAWING SHALL MEET THE REQUIREMENTS OF GRAYHILL PPAP SPECIFICATION SOP2324 CURRENT REVISION. THIS SPECIFICATION APPLIES TO PURCHASED COMPONENTS ONLY.</small>	
DESCRIPTION			
TE CABLE			
SCALE 1.000		DRAWING NUMBER T18912-X	ISSUE 2
T18912-1 #.1 PART			SHEET 2 OF 6

PAGE 3 CONTROLS T18912-3
TE-F CAN

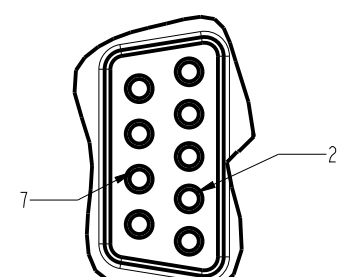
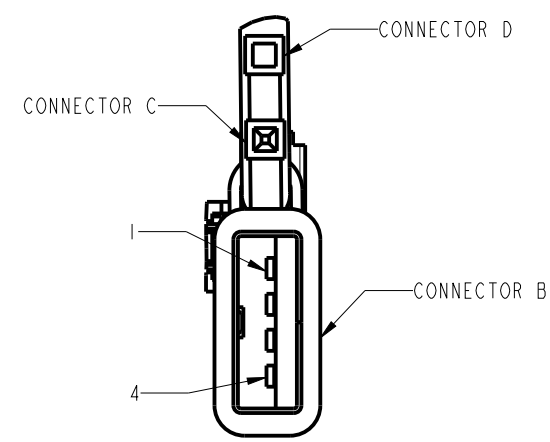
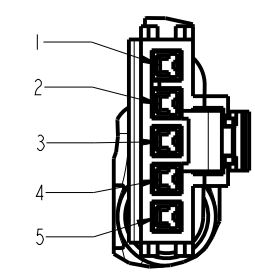
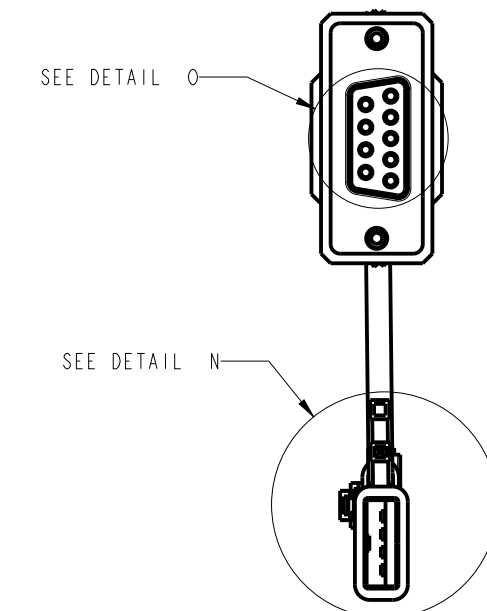
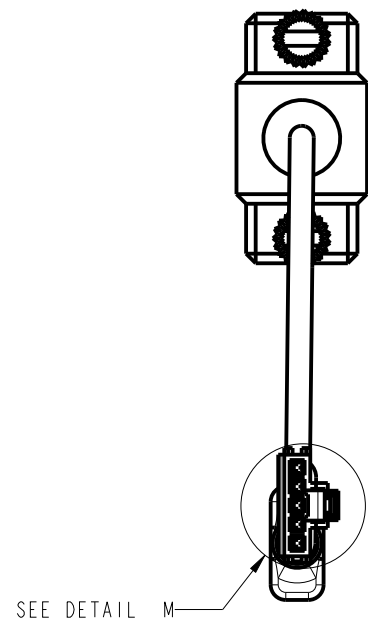
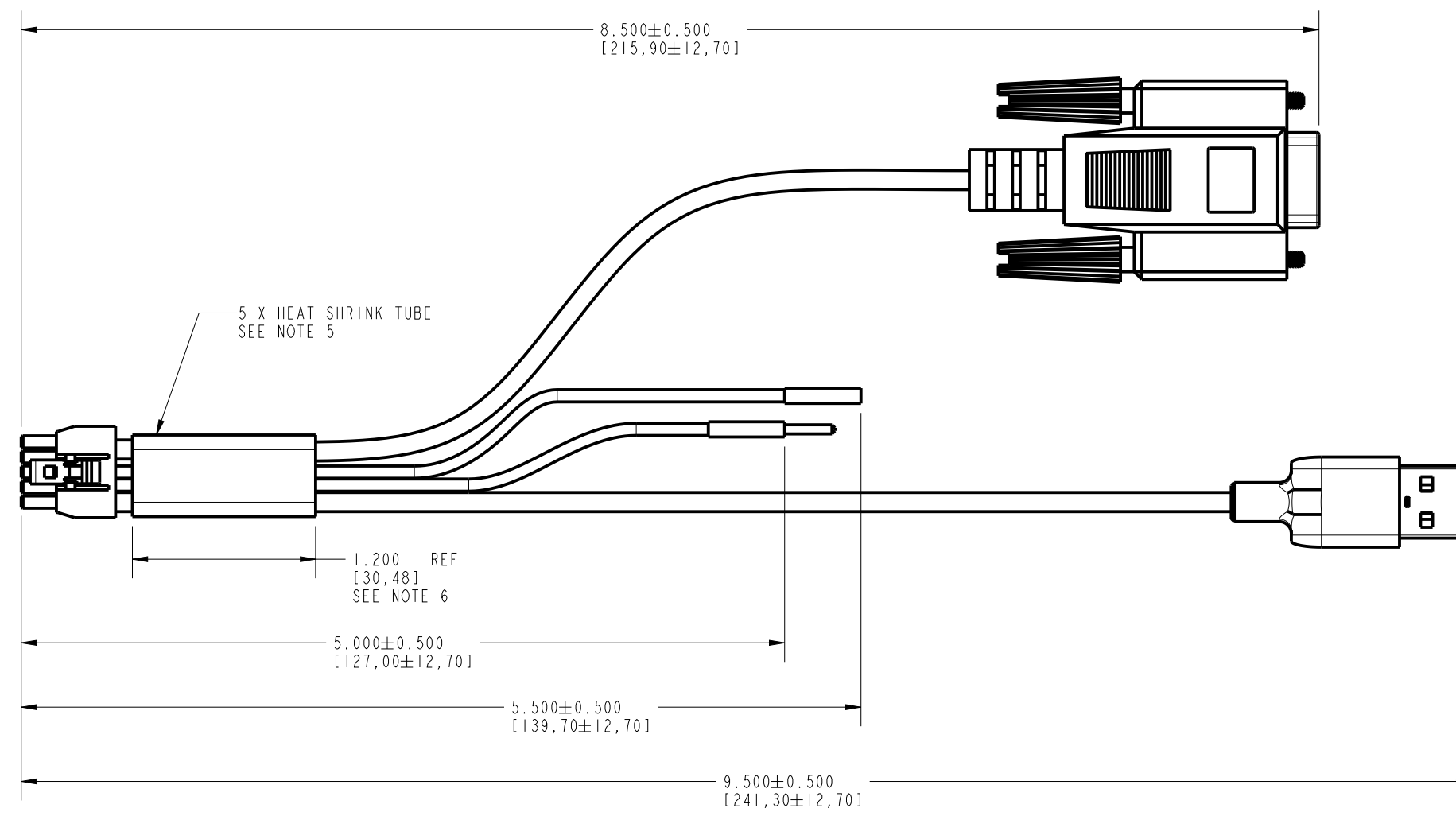
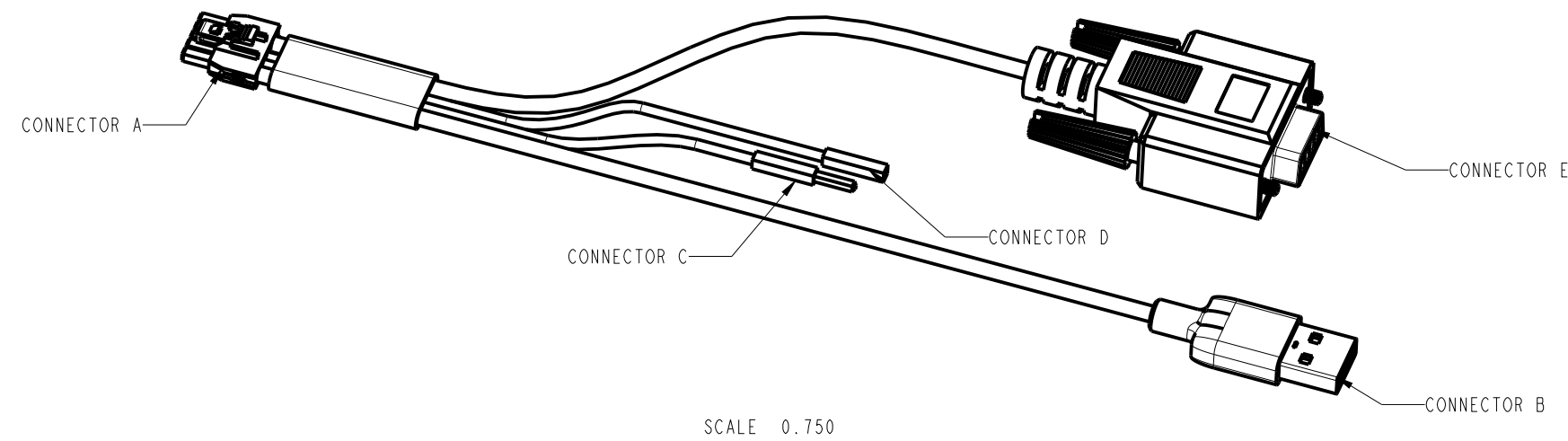

- NOTES:
- CONNECTOR:
A: MOLEX P/N: 1053071205
B: USB A MALE
C: MALE JUMPER WIRE SINGLE CONTACT HEADER (SIMILAR TO DIGIKEY: PRT-12794)
D: FEMALE JUMPER WIRE SINGLE CONTACT HEADER (SIMILAR TO DIGIKEY: PRT-12794)
E: FEMALE DB9 (SIMILAR TO DIGIKEY: MHDPPK9-DB9S-K)
 - CONNECTOR A PINS TO CONNECT TO CORRESPONDING CONNECTOR B, C, D, AND E TERMINALS ON THE CONNECTOR (SEE TABLE)
 - WIRE LENGTH SHOULD BE MEASURED WITH WIRES STRAIGHT.
 - WIRE PULLOUT FORCE MUST BE 2 LBS. MINIMUM.
 - HEAT SHRINK TUBING TO BE USED OVER ALL SOLDER CONNECTIONS.
 - EXTRA THICK HEAT SHRINK TUBING TO BE USED OVER CONNECTOR A CONNECTIONS.

WIRE #	CONNECTOR A PIN	CONNECTOR B PIN	CONNECTOR C PIN	CONNECTOR D PIN	CONNECTOR E PIN	COLOR	DESCRIPTION
1	3	N/C	1	---	N/C	UNIQUE	MODE
2	5	1	---	---	N/C	RED	PWR
3	4	4	---	1	N/C	BLK	GND
4	2	N/C	---	---	7	YELLOW	CAN H
5	1	N/C	---	---	2	GREEN	CAN L

THIS DRAWING IS AT DESIGN STATUS		ALL REVISIONS TO THIS DRAWING MUST BE MADE IN THE PRO/E SYSTEM	
DRAWING UNITS:		INCHES [MILLIMETERS]	
DRAWING TOLERANCES UNLESS OTHERWISE SPECIFIED:			
LINEAR ±	***UNDEFINED***	RADIUS ±	SAME AS DIA
DIAMETER ±	***UNDEFINED***	ANGLE ±	NA
GRAYHILL		361 W HILLGROVE AVE LA GRANGE, IL 60525 708-354-1840	3RD ANGLE PROJECTION
CRITICAL CHARACTERISTIC FLAG PER GRAYHILL SPEC. SOP2338		THIS DRAWING SHALL MEET THE REQUIREMENTS OF GRAYHILL PPAP SPECIFICATION SOP2324 CURRENT REVISION. THIS SPECIFICATION APPLIES TO PURCHASED COMPONENTS ONLY.	
DESCRIPTION			
TE CABLE			
DRAWING NUMBER		ISSUE	
T18912-X		2	
SCALE 1.000		SHEET 3 OF 6	
T18912-1 #.1 PART			

PAGE 4 CONTROLS T18912-4
TE-F USB

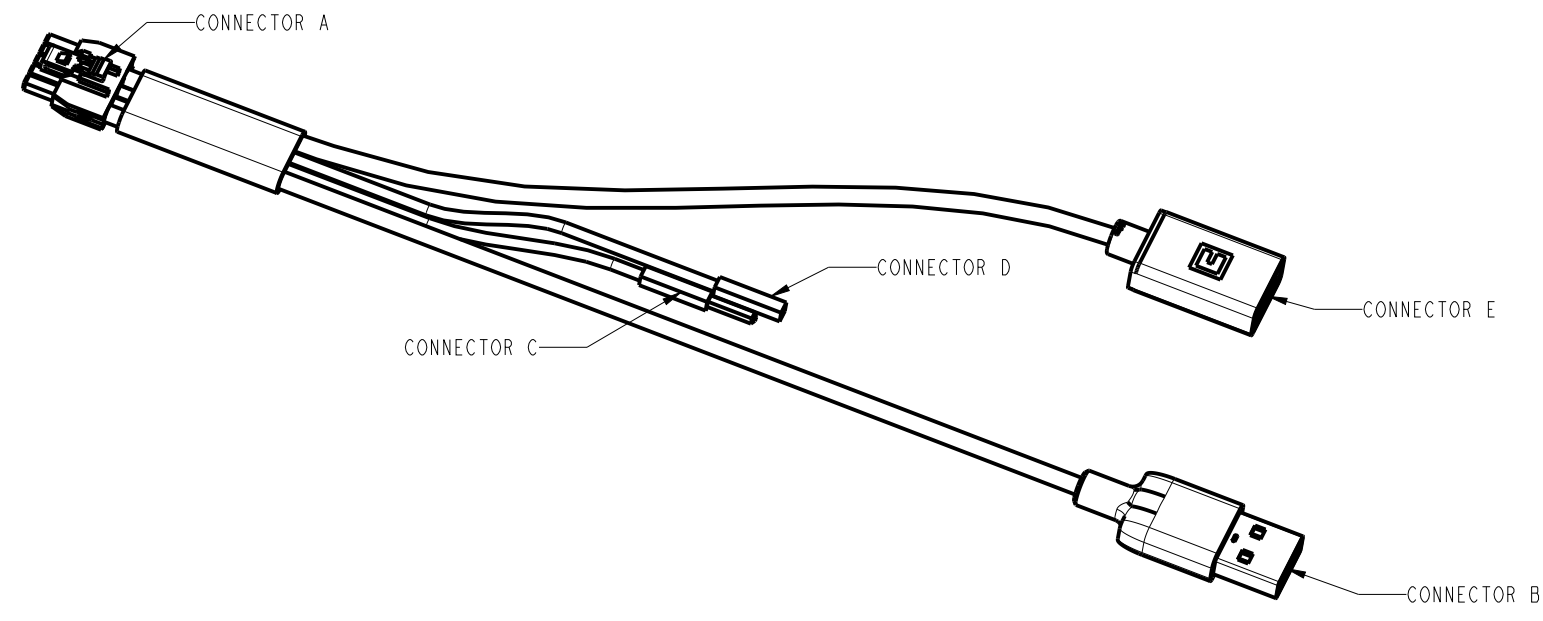

SCALE 0.750

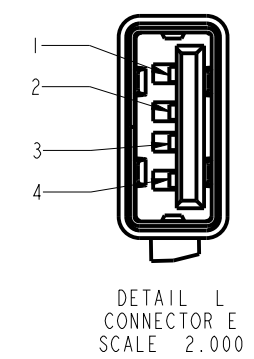
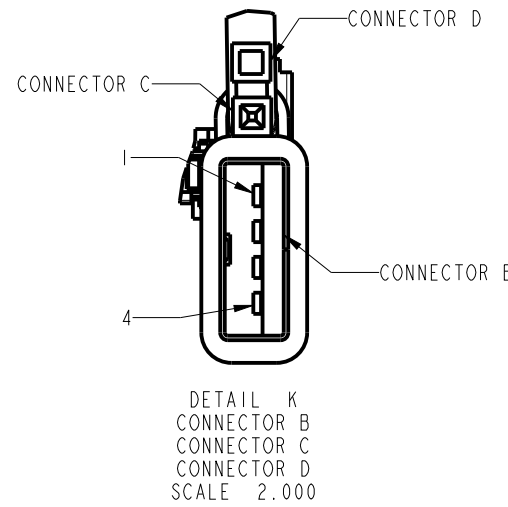
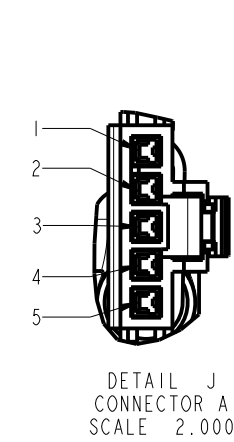
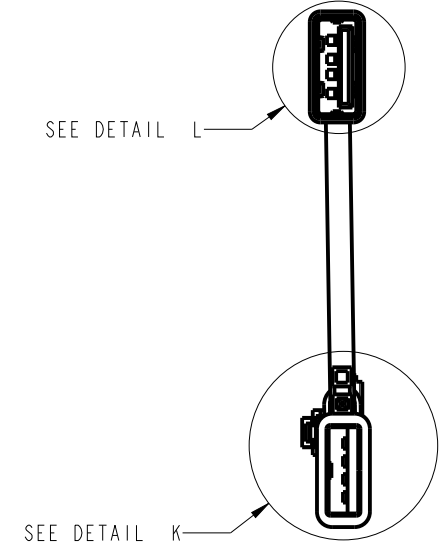
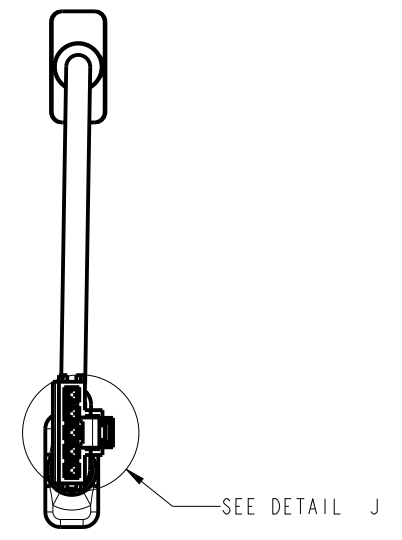
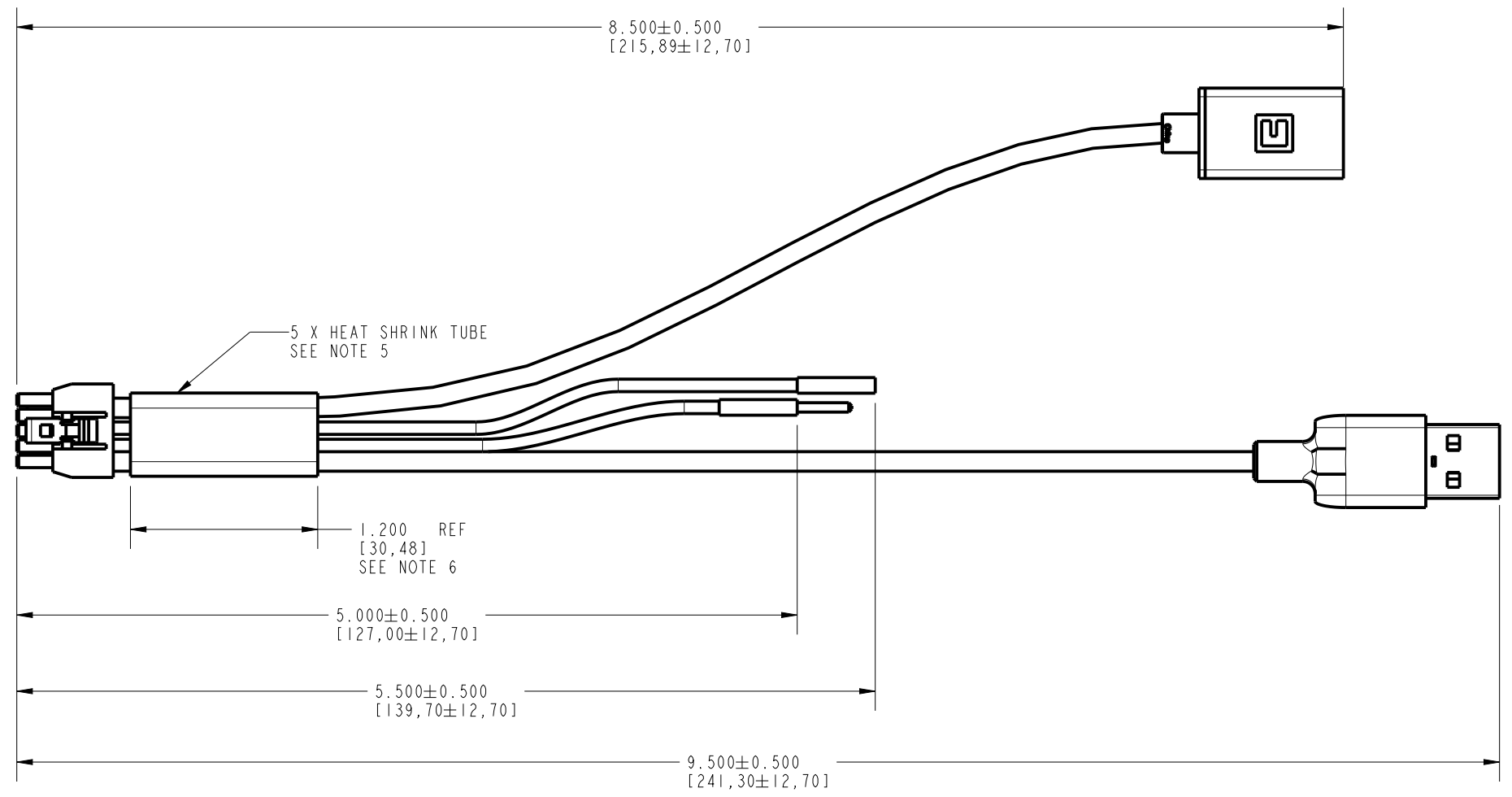

- NOTES:
- CONNECTOR:
 A: MOLEX P/N: 1053071205
 B: USB A MALE
 C: MALE JUMPER WIRE SINGLE CONTACT HEADER (SIMILAR TO DIGIKEY: PRT-12794)
 D: FEMALE JUMPER WIRE SINGLE CONTACT HEADER (SIMILAR TO DIGIKEY: PRT-12794)
 E: FEMALE USB A (SIMILAR TO DIGIKEY: 10-02336)
 - CONNECTOR A PINS TO CONNECT TO CORRESPONDING CONNECTOR B, C, D, AND E TERMINALS ON THE CONNECTOR (SEE TABLE)
 - WIRE LENGTH SHOULD BE MEASURED WITH WIRES STRAIGHT.
 - WIRE PULLOUT FORCE MUST BE 2 LBS. MINIMUM.
 - HEAT SHRINK TUBING TO BE USED OVER ALL SOLDER CONNECTIONS.
 - EXTRA THICK HEAT SHRINK TUBING TO BE USED OVER CONNECTOR A CONNECTIONS.

WIRE #	CONNECTOR A PIN	CONNECTOR B PIN	CONNECTOR C PIN	CONNECTOR D PIN	CONNECTOR E PIN	COLOR	DESCRIPTION
1	3	N/C	1	---	N/C	UNIQUE	MODE
2	5	1	---	---	1	RED	PWR
3	4	4	---	1	4	BLK	GND
4	2	N/C	---	---	3	GREEN	USB +
5	1	N/C	---	---	2	WHITE	USB -

THIS DRAWING IS AT DESIGN STATUS		ALL REVISIONS TO THIS DRAWING MUST BE MADE IN THE PRO/E SYSTEM	
DRAWING UNITS: INCHES [MILLIMETERS]		DRAWING TOLERANCES UNLESS OTHERWISE SPECIFIED:	
LINEAR ±	***UNDEFINED***	RADIUS ±	SAME AS DIA
DIAMETER ±	***UNDEFINED***	ANGLE ±	NA
GRAYHILL 361 W HILLGROVE AVE LA GRANGE, IL 60525 708-354-1800			
CRITICAL CHARACTERISTIC FLAG PER GRAYHILL SPEC. SOP2338		THIS DRAWING SHALL MEET THE REQUIREMENTS OF GRAYHILL PPAP SPECIFICATION SOP2324 CURRENT REVISION. THIS SPECIFICATION APPLIES TO PURCHASED COMPONENTS ONLY.	
DESCRIPTION			
TE CABLE			
SCALE 1.000	DRAWING NUMBER T18912-X	ISSUE 2	
T18912-2 #.1 PART			SHEET 4 OF 6

PAGE 5 CONTROLS T18912-5
TE-F CAN SEALED

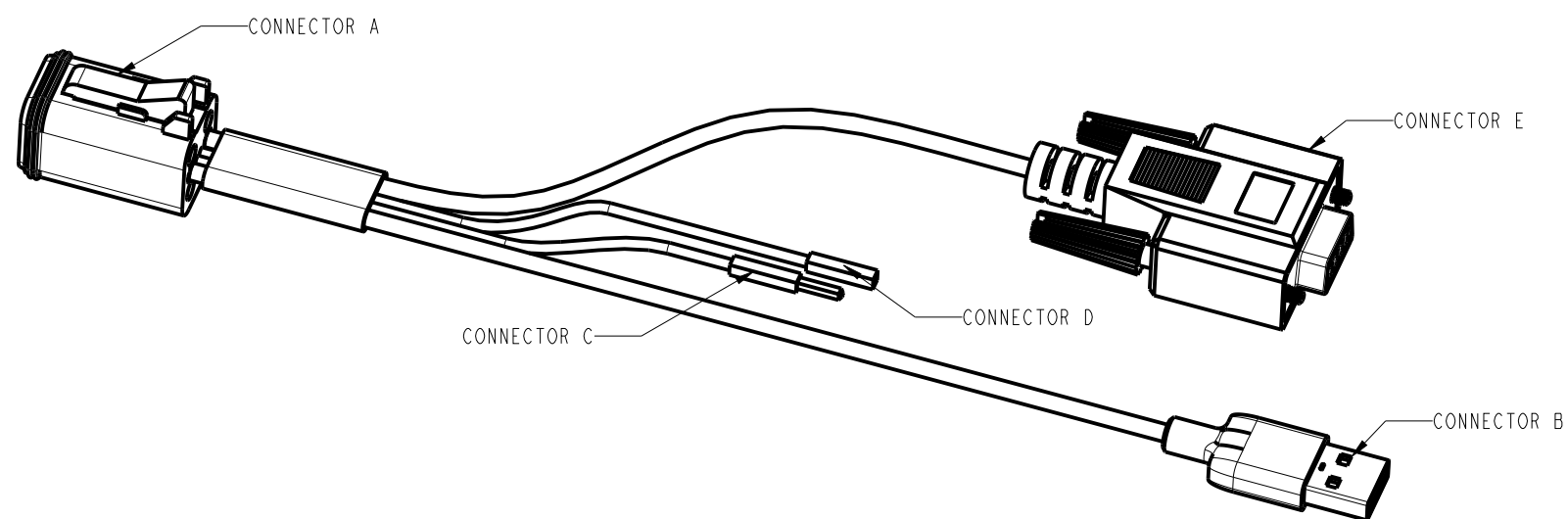

SCALE 0.750

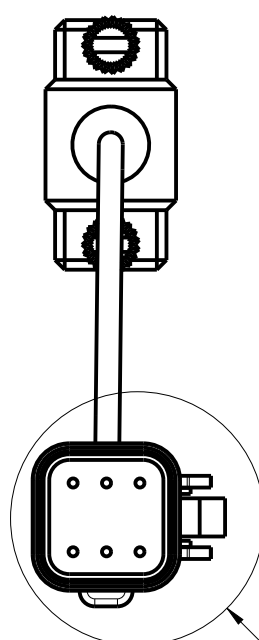
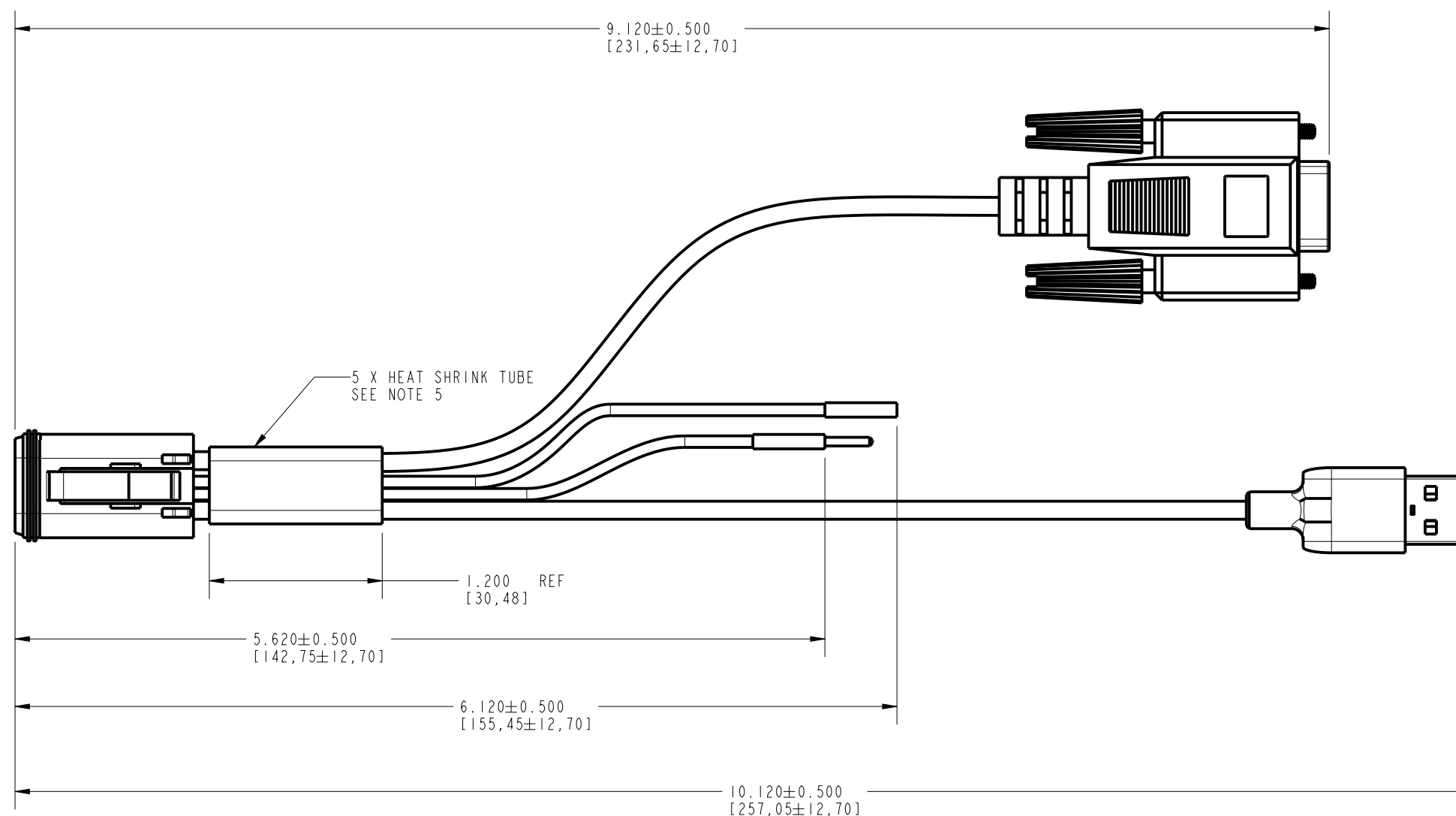

SEE DETAIL G

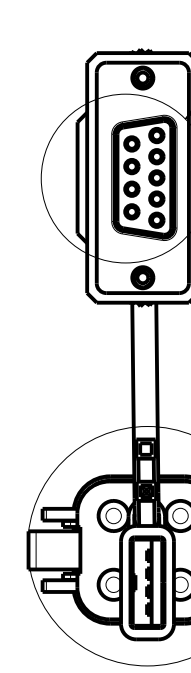

SEE DETAIL H

SEE DETAIL I

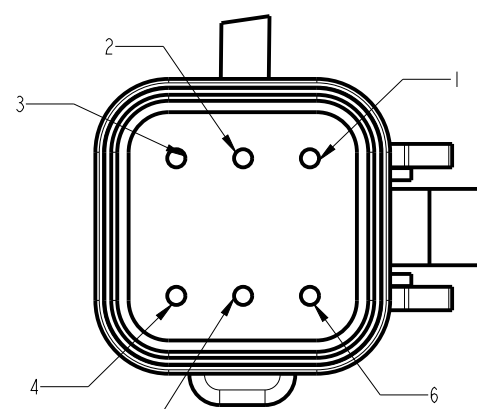

DETAIL G
CONNECTOR A
SCALE 2.000

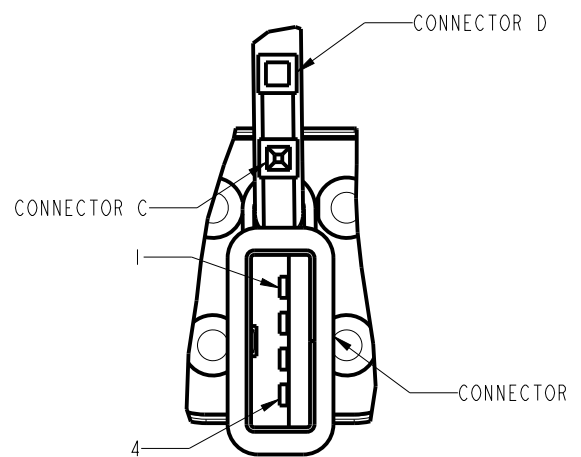

DETAIL I
CONNECTOR B
CONNECTOR C
CONNECTOR D
SCALE 2.000

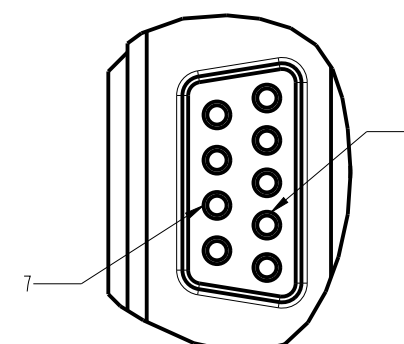

DETAIL H
CONNECTOR E
SCALE 2.000

- NOTES:
1. CONNECTOR:
A: AMPHENOL P/N: AT06-6S
B: USB A MALE
C: MALE JUMPER WIRE SINGLE CONTACT HEADER (SIMILAR TO DIGIKEY: PRT-12794)
D: FEMALE JUMPER WIRE SINGLE CONTACT HEADER (SIMILAR TO DIGIKEY: PRT-12794)
E: FEMALE USB A (SIMILAR TO DIGIKEY: 10-02336)
2. CONNECTOR A PINS TO CONNECT TO CORRESPONDING CONNECTOR B, C, D, AND E TERMINALS ON THE CONNECTOR (SEE TABLE)
3. WIRE LENGTH SHOULD BE MEASURED WITH WIRES STRAIGHT.
4. WIRE PULLOUT FORCE MUST BE 2 LBS. MINIMUM.
5. HEAT SHRINK TUBING TO BE USED OVER ALL SOLDER CONNECTIONS.
6. EXTRA THICK HEAT SHRINK TUBING TO BE USED OVER CONNECTOR A CONNECTIONS.

WIRE #	CONNECTOR A PIN	CONNECTOR B PIN	CONNECTOR C PIN	CONNECTOR D PIN	CONNECTOR E PIN	COLOR	DESCRIPTION
1	5	N/C	1	---	N/C	UNIQUE	MODE
2	1	1	---	---	N/C	RED	PWR
3	2	4	---	1	N/C	BLK	GND
4	3	N/C	---	---	7	YELLOW	CAN H
5	4	N/C	---	---	2	GREEN	CAN L

THIS DRAWING IS AT DESIGN STATUS		ALL REVISIONS TO THIS DRAWING MUST BE MADE IN THE PRO/E SYSTEM	
DRAWING UNITS: INCHES [MILLIMETERS]		DRAWING TOLERANCES UNLESS OTHERWISE SPECIFIED:	
LINEAR ±	***UNDEFINED***	RADIUS ±	SAME AS DIA
DIAMETER ±	***UNDEFINED***	ANGLE ±	NA
GRAYHILL 361 W HILLGROVE AVE LA GRANGE, IL 60525 708-354-1840			
CRITICAL CHARACTERISTIC FLAG PER GRAYHILL SPEC. SOP2338		THIS DRAWING SHALL MEET THE REQUIREMENTS OF GRAYHILL PPAP SPECIFICATION SOP2324 CURRENT REVISION. THIS SPECIFICATION APPLIES TO PURCHASED COMPONENTS ONLY.	
DESCRIPTION TE CABLE			
SCALE 0.500	DRAWING NUMBER T18912-X	ISSUE 2	
T18912-4 #.1 PART			SHEET 5 OF 6

PAGE 6 CONTROLS T18912-6
TE-F USB SEALED

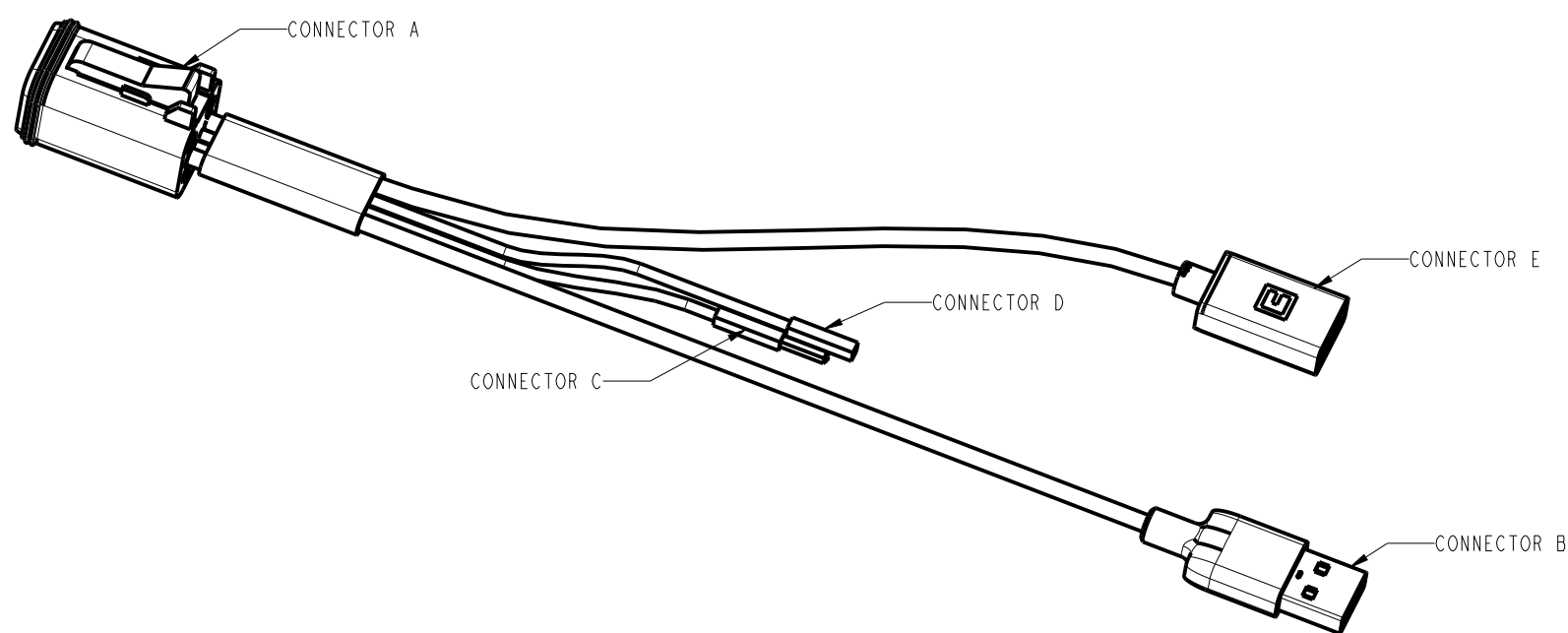

SCALE 0.750

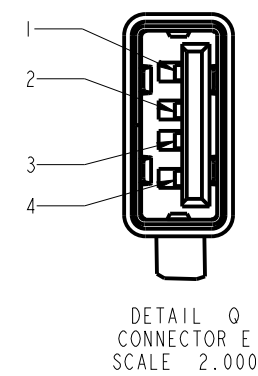
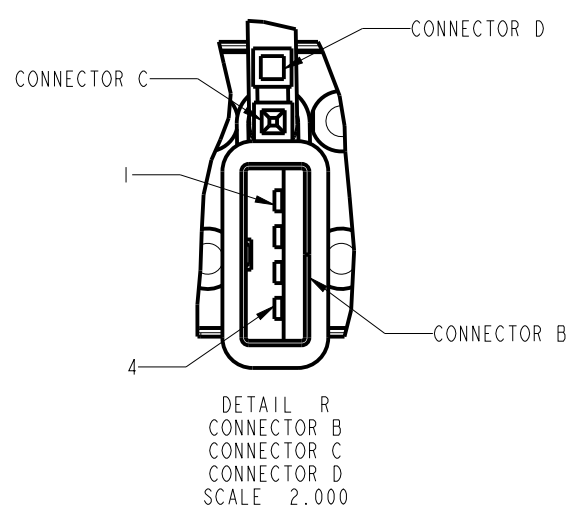
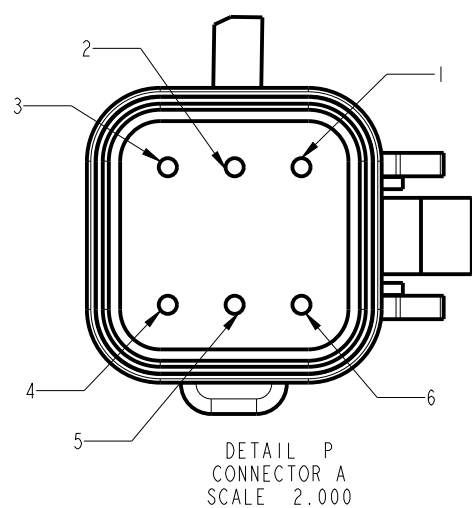
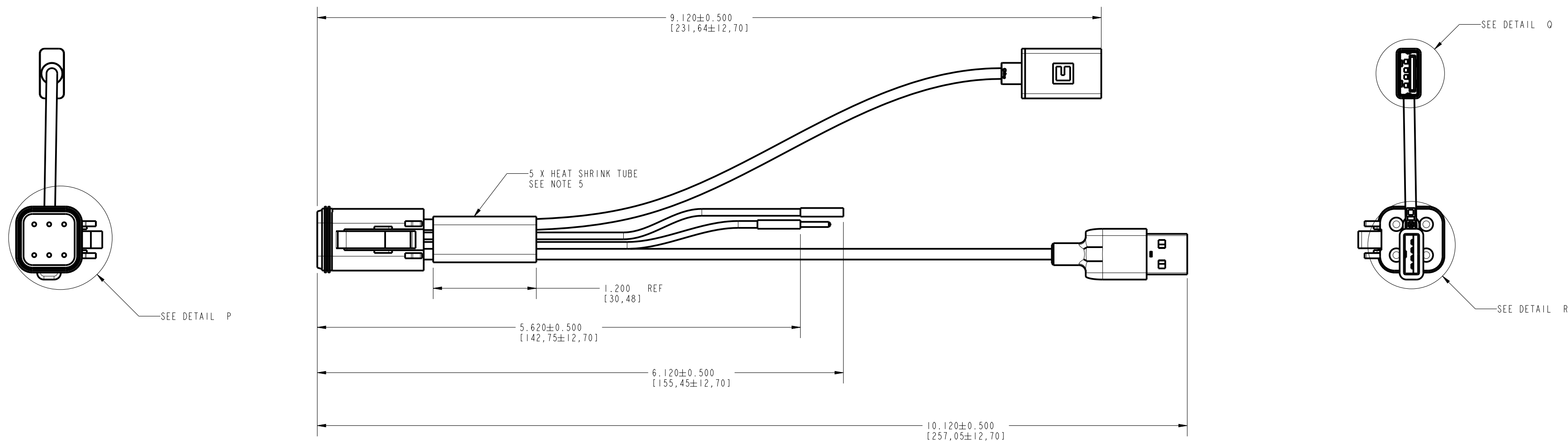

- NOTES:
- CONNECTOR:
A: AMPHENOL P/N: AT06-6S
B: USB A MALE
C: MALE JUMPER WIRE SINGLE CONTACT HEADER (SIMILAR TO DIGIKEY: PRT-12794)
D: FEMALE JUMPER WIRE SINGLE CONTACT HEADER (SIMILAR TO DIGIKEY: PRT-12794)
E: FEMALE USB A (SIMILAR TO DIGIKEY: 10-02336)
 - CONNECTOR A PINS TO CONNECT TO CORRESPONDING CONNECTOR B, C, D, AND E TERMINALS ON THE CONNECTOR (SEE TABLE)
 - WIRE LENGTH SHOULD BE MEASURED WITH WIRES STRAIGHT.
 - WIRE PULLOUT FORCE MUST BE 2 LBS. MINIMUM.
 - HEAT SHRINK TUBING TO BE USED OVER ALL SOLDER CONNECTIONS.
 - EXTRA THICK HEAT SHRINK TUBING TO BE USED OVER CONNECTOR A CONNECTIONS.

WIRE #	CONNECTOR A PIN	CONNECTOR B PIN	CONNECTOR C PIN	CONNECTOR D PIN	CONNECTOR E PIN	COLOR	DESCRIPTION
1	5	N/C	1	---	N/C	UNIQUE	MODE
2	1	1	---	---	1	RED	PWR
3	2	4	---	1	4	BLK	GND
4	3	N/C	---	---	3	GREEN	USB +
5	4	N/C	---	---	2	WHITE	USB -

THIS DRAWING IS AT DESIGN STATUS		ALL REVISIONS TO THIS DRAWING MUST BE MADE IN THE PRO/E SYSTEM	
DRAWING UNITS: INCHES [MILLIMETERS]		DRAWING TOLERANCES UNLESS OTHERWISE SPECIFIED:	
LINEAR ±	***UNDEFINED***	RADIUS ±	SAME AS DIA
DIAMETER ±	***UNDEFINED***	ANGLE ±	NA
GRAYHILL 361 W HILLGROVE AVE LA GRANGE, IL 60525 708-354-1840			
CRITICAL CHARACTERISTIC FLAG PER GRAYHILL SPEC. SOP2338		<small>THIS DRAWING SHALL MEET THE REQUIREMENTS OF GRAYHILL PPAP SPECIFICATION SOP2324 CURRENT REVISION. THIS SPECIFICATION APPLIES TO PURCHASE COMPONENTS ONLY.</small>	
DESCRIPTION TE CABLE			
DRAWING NUMBER T18912-X		ISSUE 2	
SCALE 1.000		T18912-5 #.1 PART SHEET 6 OF 6	